

## DEFULL (German (Deutschland, DE) Patents Full Text)

<b>Subject Coverage</b>	All patent-relevant areas of science and technology, i.e., all classes of the International Patent Classification	
<b>File Type</b>	Full Text	
<b>Features</b>	Thesauri	International Patent Classification (/IPC) and Cooperative Patent Classification (/CPC)
	<a href="#">Alerts (SDIs)</a>	Weekly or monthly (weekly is the default)
	CAS Registry Number® Identifiers	<input type="checkbox"/> Page Images <input checked="" type="checkbox"/>
	<a href="#">Keep &amp; Share</a>	<input checked="" type="checkbox"/> SLART <input checked="" type="checkbox"/>
	Learning Database	<input type="checkbox"/> Structures <input type="checkbox"/>
<b>Record Content</b>	<ul style="list-style-type: none"> <li>• Full text of patent applications and granted patents in Germany from application publication year 1877 onwards.</li> <li>• Records are available about a week after publication with the complete content.</li> <li>• Records contain bibliographic data including patent applicant and inventor, patent, application, priority, and related application data, IPC and CPC classification codes, abstract and full text of description and claims.</li> <li>• Titles, Abstracts, Descriptions and Claims are available in German and machine translated to English. Documents with the kind codes DET (most of them DET2) – translations of WO-applications and EP-patents transferred to Germany – have the full text only German. These WO-applications and EP-patents with the original English text are searchable in PCTFULL and EPFULL.</li> <li>• Numeric values of 55 physical and chemical properties are searchable in about 1800 unit variants within all full text fields in English.</li> <li>• Database records comprise all documents published for one application.</li> <li>• Legal status data, patent and non-patent citations, and family display formats from the INPADOCDB database are available.</li> <li>• Some of the full text has been created by Optical Character Recognition (OCR) software. Therefore, characters may be misinterpreted, or portions of the text may be incomplete.</li> </ul>	
<b>File Size</b>	<ul style="list-style-type: none"> <li>• More than 5.7 million family records with more than 7.0 million publications (07/2020)</li> <li>• More than 4.6 million front page images from 1877 to present (07/2020)</li> </ul>	
<b>Coverage</b>	Comprehensive 1877 to present	
<b>Updates</b>	Weekly	
<b>Language</b>	English, German	
<b>Database Producer</b>	LexisNexis Univentio BV Galileiweg 8 2333 BD Leiden The Netherlands Phone: (+31) 88-6390000 Email: <a href="mailto:customersupport@univentio.com">customersupport@univentio.com</a> Copyright Holder	

**DEFULL****Database  
Supplier**

FIZ Karlsruhe  
STN Europe  
P.O. Box 2465  
76012 Karlsruhe  
Germany  
Phone: +49-7247-808-555  
Fax: +49-7247-808-259  
Email: [helpdesk@fiz-karlsruhe.de](mailto:helpdesk@fiz-karlsruhe.de)

---

**Sources**

Patent applications, granted patents, and utility models published by the Reichspatentamt and the Deutsche Patent- und Markenamt (DPMA) in Germany (country code DE).

---

**User Aids**

- Online Helps (HELP DIRECTORY lists all help messages available)
  - STNGUIDE
- 

**Clusters**

- AEROTECH
- ALLBIB
- AUTHORS
- CORPSOURCE
- ENGINEERING
- FULLTEXT
- HPATENTS
- NPS
- PATENTS
- PNTTEXT

STN Database Cluster information:

<http://www.stn-international.com/en/customersupport/customer-support#cluster+%7C+subjects+%7C+features>

---

## Search and Display Field Codes

If multiple search terms are linked with and AND-operator, all terms are searched in the complete database record, i.e. in all publications referring to one application. For a search in a specific publication of the record, connect the search term and the patent kind code with the (L)-proximity operator, e.g., S BOREHOLE/AB, TI, CLM (L) DEA1/PK limits the search to German applications DEA1.

Fields that allow left truncation are indicated by an asterisk (\*).

### General Search Fields

Search Field Name	Search Code	Search Examples	Display Codes
Basic Index* (contains single words from title (TI), abstract (AB), detailed description (DETD), claims (CLM), and main claims (MCLM) fields)	None or /BI	S TRANSISTOR AND ELECTRODE S ACOUSTIC SENSOR S ?TRANSFER?	TI, AB, ABDE, ABEN, DETD, DETDDE, DETDEN, CLM, CLMDE, CLMEN, MCLM, MCLMDE, MCLMEN
Abstract (German and English) * Abstract (German) * Abstract (English) * Accession Number Application Country (WIPO code and text) Application Date (1) Application Number (2)  Application Number, Original Application Year (1) Claims (German and English) * Claims (German) * Claims (English) * Cooperative Patent Classification (3) Cooperative Patent Classification, Action Date Cooperative Patent Classification, Keyword Cooperative Patent Classification, Version Document Type (code and text) Entry Date (1) Entry Date of Full-text (1) Field Availability Graphic Image Size Graphic Image Type International Patent Classification (ICM, ICS, IPCI, IPCR) (3) International Patent Classification (ICM, ICS) Inventor  Inventor, Country (WIPO code and text) IPC, Initial IPC, Keyword Terms IPC, Main IPC, Reclassified IPC, Reform IPC, Secondary IPC, Version Language (code and text) Language, Filing (code and text)	/AB /ABDE /ABEN /AN /AC  /AD /AP (or /APPS) /APO /AY /CLM /CLMDE /CLMEN /CPC /CPC.ACD  /CPC.KW /CPC.VER /DT (or /TC) /ED /EDTX /FA /GIS /GIT /IPC  /IC /IN (or /AU) /IN.CNY /IPCI /IPC.KW /ICM /IPCR /IPC.REF /ICS /IPC.VER /LA /LAF	S BOREHOLE/AB S BOHRMAS,CHINEN/ABDE S BOREHOLE/ABEN S 2011000109/AN S DE/AC  S AD=JAN 2011 S DE2011-102011077851/AP  S DE20112352U/APO S AY>=2005 S DERIVATION/CLM S BACKENBREMSE/CLMDE S DERIVATION/CLMEN S C12N0009/CPC S 20121113/CPC.ACD  S C12N0009/CPC (S) I/CPC.KW S 20130101/CPC.VER S P/DT S PATENT/DT S ED=DEC 2013 S 20131201/EDTX S AB/FA S 2016/GIS S TIFF/GIT S A01B0001-16/IPC  S A47J051-06/IC S BAAR HEINZ JOACHIM/IN S MUELLER A?/IN S DE/IN.CNY S B21B0001/IPCI S INITIAL/IPC.KW S B29B001-06/ICM S B21D0007-08/IPCR S A01B0001-16/IPC.REF S B29H003-00/ICS S 7/IPC.VER S DE/LA S GERMAN/LAF	AB ABDE, AB ABEN, AB AN AI  AI AI  APO AI CLM CLMDE, CLM CLMEN, CLM CPC CPC.TAB  CPC.TAB CPC.TAB DT  ED EDTX FA GIS GIT ICM, ICS, IPCI, IPCR IC, ICM, ICS IN  IN, IN.CNY IPCI, IPC IPC.TAB ICM, IC IPCR, IPC IPC.TAB ICS, IC IPC.TAB LA LAF

## General Search Fields (cont'd)

Search Field Name	Search Code	Search Examples	Display Codes
Main Claim (German and English) * Main Claim (German) *	/MCLM /MCLMDE	S ?FRACTURE?/MCLM S FRAESEN/MCLMDE	MCLM MCLMDE, MCLM
Main Claim (English) *	/MLCMEN	S ?FRACTURE?/MLCMEN	MLCMEN, MCLM
Number of Claims (1) Number of Paragraphs in DETD (Detailed Description) (1) Patent Applicant/Patentee (4)	/CLMN /DETN  /PA (or /CS)	S 5-7/CLMN S DETN<10  S DAIMLER BENZ AG/PA	CLMN DETN  PA
Patent Applicant, Country Patent Country (WIPO code and text) Patent Information Publication Type	/PA.CNY /PC /PIT	S DE/PA.CNY S DE/PC S DEA8 CORRECTED FIRST PAGE/PIT	PA, PA.CNY PI PIT
Patent Kind Code Patent Number (2)	/PK /PN (or /PATS)	S DEA1/PK S DE 20100026/PN	PI PI
Patent Number, Original Patent Number/Kind Code Physical Properties Priority Country (WIPO code and text) Priority Date (1)	/PNO /PNK /PHP /PRC  /PRD	S DE 20100026/PNO S DE20111497 U1/PNK S PHV/PHP (S) BUFFER/BI S DE/PRC S GERMANY/PRC S PRD=MAY, 20 2003 S 20030520/PRD	PNO PI KWIC PRN  PRN
Priority Date, First (1) Priority Number (2) Priority Number, Original Priority Year (1) Priority Year, First (1) Publication Date (1) Publication Year (1) Related Patent Country Related Application Number Related Application Date (1) Related Application Year (1) Title (German and English)* Title (German) * Title (English) * Update Date (1)	/PRDF /PRN /PRNO /PRY /PRYF /PD /PY /RLC /RLN /RLD /RLY /TI /TIDE /TIEN /UP	S 20010704/PRDF S AT2005-1585/PRN S US10283008P/PRNO S 2003/PRY S 2003-2004/PRYF S PD=MARCH-APRIL 2011 S PY>2008 AND L1 S WO/RLC S WO2005-CN2240/RLN S 20050701/RLD S 2005/RLY S FLUID###/TI S FLUGZEUGE/TIDE S FLUORIDE/TIEN S UP=JUNE 2013	PRN PRN PRNO, PRAO PRN PRN PI PI RLI RLI RLI RLI TI TIDE, TI TIEN, TI UP

(1) Numeric search field that may be searched using numeric operators or ranges.

(2) By default, patent numbers, application and priority numbers are displayed in STN Format. To display them in Derwent format, enter SET PATENT DERWENT at an arrow prompt. To reset display to STN Format, enter SET PATENT STN.

(3) An online thesaurus is available in this field.

(4) Search with implied (S) proximity is available in this field.

## Super Search Fields

Enter a super search code to execute a search in one or more fields that may contain the desired information. Super search fields facilitate crossfile and multifile searching. EXPAND may not be used with super search fields. Use EXPAND with the individual field codes instead.

Search Field Name	Search Code	Fields Searched	Search Examples	Display Codes
Application Number Group	/APPS	AP, PRN	S DE2011-102011077851/APPS	AI, PRAI, APPS

## Property Fields<sup>1)</sup>

In DEFULL a numeric search for a specific set of physical properties (/PHP) is available within the full text fields in English (TIEN, ABEN, DETDEN, CLMEN as well as English text in TI, AB, CLM, DETD, BI). The numeric values are not displayed as single fields, but highlighted within the hit displays.

Use EXPAND/PHP to search for all available physical properties. A search with the respective field codes will be carried out in all database fields with English text. The /PHP index contains a complete list of codes and related text for all physical properties available for numeric search.

Field Code	Property	Unit	Symbol	Search Examples
/AOS	Amount of substance	Mol	mol	S 10 /AOS
/BIR	Bit Rate	Bit/Second	bit/s	S 8000-10000/BIR
/BIT	Stored Information	Bit	Bit	S BIT > 3 MEGABIT
/CAP	Capacitance	Farad	F	S 1-10 MF/CAP
/CDN	Current Density	Ampere/Square Meter	A/m <sup>2</sup>	S CDN>10 A/M**2
/CMOL	Molarity, Molar Concentration	Mol/Liter	mol/L	S UREA/BI (S) 8/CMOL
/CON	Conductance	Siemens	S	S 1S-3/CON
/DB	Decibel	Decibel	dB	S DB>50
/DEG	Degree	Degree	°	S CYLINDER/BI (S) 45/DEG
/DEN	Density (Mass Concentration)	Kilogram/Cubic Meter	kg/m <sup>3</sup>	S 5E-3-10E-3/DEN
/DEQ	Dose Equivalent	Sievert	Sv	S 100/DEQ
/DOS	Dosage	Milligram/Kilogram	mg/kg	S DOS>0.8
/DV	Viscosity, dynamic	Pascal * Second	Pa * s	S DV>5000
/ECD	Electric Charge Density	Coulomb/Square Meter	C/m <sup>2</sup>	S ECD>10
/ECH	Electric Charge	Coulomb	C	S 0.0001-0.001/ECH
/ECO	Electrical Conductivity	Siemens/Meter	S/m	S ECO>800 S/M (15A) AQUEOUS
/ELC	Electric Current	Ampere	A	S 1-10/ELC
/ELF	Electric Field	Volt/Meter	V/m	S 200/ELF
/ENE	Energy	Joule	J	S DROPLETS (10A) 20 JOULE - 30 JOULE /ENE
/ERE	Electrical Resistivity	Ohm * Meter	Ohm * m	S ERE>0.1
/FOR	Force	Newton	N	S 50 N /FOR
/FRE	Frequency	Hertz	Hz	S OSCILLAT?/BI (S) 1- 3/FRE
/IU	International Unit	none	IU	S IU>1000 (P) VITAMIN A
/KV	Viscosity, kinematic	Square Meter/Second	m <sup>2</sup> /s	S POLYETHYLENE WAX/BI (6A) 10E-5 M**2/S /KV
/LEN (or /SIZ)	Length, Size	Meter	m	S 1-4/LEN
/LUME	Luminous Emittance, Illuminance	Lux	lx	S 10-50/LUME
/LUMF	Luminous Flux	Lumen	Lm	S LUMF>1000
/LUMI	Luminous Intensity	Candela	cd	S LUMI<4
/M	Mass	Kilogram	kg	S ALLOY/BI (30A) 1E-10-1E-5/M
/MCH	Mass to Charge Ratio	none	m/z	S MCH=1
/MFD (or /MFS)	Magnetic Flux Density	Tesla	T	S MFD>102
/MFR (or /MFL)	Mass Flow Rate	Kilogram/Second	kg/s	S MFR<0.1
/MM	Molar Mass	Gram/Mol	g/mol	S 2000-3000 G/MOL/MM
/MOLS	Molality of Substance	Mol/Kilogram	mol/kg	S 01.-10 MOL/KG/MOLS
/MVR	Melt Volume Rate, Melt Flow Rate	none	g/10 min	S 3/MVR
/NUC	Nutrition Content	none	g/100 kcal	S NUC<100 (P) NUTRIENT
/PER	Percent (Proportionality)	none	%	S POLYMER?/AB (5A) 4/PER
/PERA	Permittivity, Absolute	Farad/Meter	F/m	S 300/PERA

### Property Fields<sub>1)</sub> (cont'd)

Field Code	Property	Unit	Symbol	Search Examples
/PHV	pH Value	pH	pH	S 7.4-7.6/PHV
/POW	Power	Watt	W	S "HG-XE-?"BI (S) 300-400 WATT/POW
/PRES (or /P)	Pressure	Pascal	Pa	S (VACUUM (5A) DISTILL?)BI (S) 1000-1100/PRES
/RAD	Radioactivity	Becquerel	Bq	S RAD/PHP
/RES	Electrical Resistance	Ohm	Ohm	S SENSOR/BI (S) 10- 100/RES
/RSP	Rotational Speed	Revolution/Minute	rpm	S 2 RPM - 100 RPM /RSP (S) ENGINE/BI
/SAR	Area /Surface Area	Square Meter	m <sup>2</sup>	S BEDPLATE/BI (S) 10 M**2 - 100 M**2 /SAR
/SOL	Solubility	Gram/100 gram	g/100 g	S SOL>20 G/100G (5A) WATER
/STSC	Surface Tension	Joule /Square Meter	J/m <sup>2</sup>	S 60 J/M**2/STSC
/TCO	Thermal Conductivity	Watt/Meter * Kelvin	W/m * K	S 1/TCO (S) HEAT?
/TEMP (or /T)	Temperature	Kelvin	K	S 20-25/TEMP
/TIM	Time	Second	s	S ?INCUB?/BI (10A) 50 S - 150 S /TIM
/VEL (or /V)	Velocity	Meter per Second	m/s	S REDUC?/BI (S) 1E-3-5E-3/VEL
/VELA	Velocity, angular	Radian/Second	rad/s	S VELA>10
/VLR	Volumetric Flow Rate	Cubic Meter/Second	m <sup>3</sup> /s	S 1 M**3/S - 2 M**3/S /VLR (S) ABRASIVE SUBSTANCE
/VOL	Volume	Cubic Meter	m <sup>3</sup>	S 1E-8-2E-8/VOL.EX
/VOLT	Voltage	Volt	V	S TENSION/BI (10A) 5E-3 V <VOLT<7E-3 V

1) Exponential format is recommended for the search of particularly high or low values, e.g. 1.8E+7 or 1.8E7 (for 18000000) or 9.2E-8 (for 0.00000092).

### International Patent Classification (/IPC) Thesaurus

The classifications, validity and catchwords for the main headings and subheadings from the current (8th) edition of the WIPO International Patent Classification (IPC) manual are available. The classifications from the previous editions (1-7) are also available as separate thesauri. To EXPAND and SEARCH in the thesauri for editions 1–7, use the field code followed by the edition number, e.g., /IPC2, for the 2nd edition. Catchwords are included only in the thesauri for the 8th, 7th, 6th, and 5th editions.

Code	Content	Examples
ADVANCED (ADV)	Advanced Codes for the Core Level IPC Code	E A61K0006-06+ADVANCED/IPC
ALL	All Associated Terms (BT, SELF, NT, RT)	E C01C003-00+ALL/IPC
BRO (MAN)	Complete Class	E C01C+BRO/IPC
BT	Broader Term (BT, SELF)	E C01F001-00+BT/IPC
CORE (COR)	Core Codes for the Advanced Level IPC Code	E G08C0019-22+CORE/IPC
ED	Complete title of the SELF term and IPC manual edition	E C01F001-00+ED/IPC
HIE	Hierarchy Term (Broader and Narrower Term) (BT, SELF, NT)	E C01B003-00+HIE/IPC
INDEX	Complete title of the SELF term	E C01F001-00+INDEX/IPC
KT	Keyword Term (catchwords) (SELF, KT)	E CYANOGEN+KT/IPC
NEXT	Next Classification	E C01C001-00+NEXT5/IPC
NT	Narrower Terms (SELF, NT)	E C01C+NT/IPC
PREV	Previous Classification	E C01C001-12+PREV10/IPC
RT (SIB)	Related Terms (SELF, RT)	E C01C003-20+RT/IPC
TI	Complete Title of the SELF Term and Broader Terms (BT, SELF)	E C01F001-00+TI/IPC

## CPC Thesaurus

This thesaurus is available in the /CPC search field. All relationship codes can be used with both the EXPAND and SEARCH commands.

Relationship Code	Content	Search Examples
ALL	All usually required terms (BT, SELF, CODE, DEF)	E A61K0031-4375+ALL/CPC
AUTO (1)	Automatic relationship (BT, SELF, CODE, DEF)	E C07D0473-40+AUTO/CPC
BT	Broader terms (BT, SELF)	E C12N0009-6464+BT/CPC
CODE	Classification Code (SELF, CODE)	E CARTRIDGES+CODE/CPC
DEF	Definition (SELF, DEF)	E B65G0045-16+DEF/CPC
HIE	Hierarchy terms (all broader and narrower terms) (BT, SELF, DEF, NT)	E F02M0031-047+HIE/CPC
KT	Keyword terms (SELF, KT)	E LASER+KT/CPC
MAX	All associated terms	E G01R0022-066+MAX/CPC
NEXT	Next classification within the same class (SELF, NEXT)	E A01N0041-04+NEXT/CPC
NEXT(n)	Next n classification within the same class	E A01N0041-04+NEXT3/CPC
NT	Narrower terms	E C07D0473-40+NT/CPC
PREV	Previous Code within the same class (SELF, PREV)	E F05C2253-16+PREV/CPC
PREV(n)	Previous n classifications within the same class	E F05C2253-16+PREV2/CPC
TI	Complete Title of SELF Term and Broader Terms (BT, SELF)	E F05B2250-313+TI/CPC

(1) Automatic Relationship is SET OFF. In case of SET REL ON the result of EXPAND or SEARCH without any relationship code is the same as described for AUTO.

## DEFULL

**DISPLAY and PRINT Formats**

Any combination of formats may be used to display or print answers. Multiple codes must be separated by spaces or commas, e.g., D L1 1-5 TI PA. The fields are displayed or printed in the order requested.

The information of the latest publication is displayed by default. To display the content for all levels of the record you can combine all display fields and formats with the qualifier .M except FA, FAM, CFAM, SCAN, and TRIAL.

For displaying a particular publication of a database record, you can simply add for certain display field the kind code to the appropriate display format, e.g. ALL.A. Fields that allow this are indicated by a number (3).

Hit-term highlighting is available for all fields. Highlighting must be ON during SEARCH to use the HIT, KWIC, and OCC formats.

The default display format is STD.M, i.e., all publication levels of one family in the STD format.

Format	Content	Examples
AB (ABS)	Abstract (German and English)	D TI AB 1-5
ABDE	Abstract (German)	D ABDE
ABEN	Abstract (English)	D ABEN
AI (AP) (1)	Application Information	D AI
AN	Accession Number	D L3 AN
APO	Application Number, Original	D APO
CLM (3)	Claims (German and English)	D CLM
CLMDE (3)	Claims (German)	D CLMDE
CLMEN (3)	Claims (English)	D CLMEN
CLMN (2)	Number of Claims	D CLMN
CPC	Cooperative Patent Classification	D CPC
DETD (3)	Detailed Description	D DETD
DETDDE (3)	Detailed Description in German	D DETDDE
DETDEN (3)	Detailed Description in English	D DETDEN
DETN (2)	Number of Paragraphs in DETD	D DETN
DT (TC)	Document Type	D DT
ED	Entry Date	D ED
EDTX	Entry Date of Full-text	D EDTX
FA	Field Availability (for all publication levels)	D FA
GI	Graphic Image	D GI
GIS (2)	Graphic Image, Size	D GIS
GIT (2)	Graphic Image, Type	D GIT
IC	IPC (format contains ICM, ICS)	D IC
ICM	IPC, Main	D ICM
ICS	IPC, Secondary	D ICS
IN (AU)	Inventor (in English)	D IN
IN.CNY	Inventor, Country	D IN.CNY
IPCI	IPC, Initial	D IPCI
IPCR	IPC, Reclassified	D IPCR
LA	Language	D LA
LAF	Language of Filing	D LAF
MCLM	Main Claim (German and English)	D MCLM
MLCMDE	Main Claim (German)	D MCLMDE
MCLMEN	Main Claim (English)	D MCLMEN
PA (CS)	Patent Applicant/Patentee	D PA
PA.CNY	Patent Applicant, Country	D PA.CNY
PI (PN, PATS) (1)	Patent Information	D PI
PIT	Patent Information Publication Type	D PIT
PNO	Patent Number, Original Format	D PNO
PRN (PRAI) (1,5)	Priority Information	D PRN
PRNO (PRAO) (2)	Priority Number, Original Format	D PRNO
RLI (RLN)	Related Patent Information	D RLI
TI	Title (German and English)	D TI
TIDE	Title (German)	D TIDE
TIEN	Title (English)	D TIEN
UP	Update Date	D UP
ALL (1)	AN, ED, EDTX, UP, TI, IN, IN.CNY, PA, PA.CNY, LAF, LA, DT, PIT, PI, AI, RLI, PRAI, IPC, CPC, AB, DETD, CLM	D ALL
ALLG (1)	ALL, plus graphic image	D ALLG
IALL (1)	ALL, indented with text labels	D IALL



**DISPLAY and PRINT Formats (cont'd)**

<b>Format</b>	<b>Content</b>	<b>Examples</b>
IALLG (1) DALL (1) APPS BIB (3)	IALL, plus graphic image ALL, delimited for post processing AI, RLN, PRAI AN, ED, EDTX, UP, TI, IN, IN.CNY, PA, PA.CNY, LAF, LA, DT, PIT, PI, AI, RLI, PRAI	D IALLG D DALL D APPS D BIB
BIBG IBIB (3) IBIBG	BIB, plus graphic image BIB, indented with text labels IBIB, plus graphic image	D BIBG D IBIB D IBIBG
CPC.TAB BRIEF (1)	CPC, CPC.KW, CPC.VER, CPC.ACD in tabular version AN, ED, EDTX, UP, TI, IN, IN.CNY, PA, PA.CNY, LAF, LA, DT, PIT, PI, AI, RLI, PRAI, IPC, CPC, AB, MCLM	D BRIEF
BRIEFG (1) IBRIEF (1) IBRIEFG (1)	BRIEF, plus graphic image BRIEF, indented with text labels IBRIEF, plus graphic image	D BRIEFG D IBRIEF D IBRIEFG
FAM (1) CFAM (1)	AN, table of patent family information (from INPADOCDB) AN, Condensed family format (from INPADOCDB)	D FAM D CFAM
IND IPC IPC.TAB	ED, IPC (ICM, ICS, IPCI, IPCR), CPC International Patent Classification (ICM, ICS, IPCI, IPCR) IPC, IPC.KW, IPC.VER, IPC.ACD in tabular version	D IND D IPC D IPC.TAB
LS LS2 MAX (ALL.M) (1)	Legal Status (from INPADOCDB) Legal Status (from INPADOCDB), detailed version with display header AN, ED, EDTX, UP, TI, IN, IN.CNY, PA, PA.CNY, LAF, LA, DT, PIT, PI, AI, RLI, PRAI, IPC, CPC, AB, DETD, CLM, FA for all levels of publication	D LS D LS2 D MAX
MAXG (ALLG.M) (1) IMAX (IALL.M) (1) IMAXG (IALLG.M) (1)	MAX, plus graphic image MAX, indented with text labels IMAX, plus graphic image	D MAXG D IMAX D IMAXG
RE SCAN (4) STD (1)	Citations (from INPADOCDB) TI (random display without answer numbers) AN, ED, EDTX, UP, TI, IN, IN.CNY, PA, PA.CNY, LAF, LA, DT, PIT, PI, AI, RLI, PRAI, IPC, CPC (STD.M is default)	D RE D SCAN D STD
STDG (1) ISTD (1) ISTDG (1) TRIAL (TRI, SAM, SAMPLE, FREE) TX	STD, plus graphic image STD, indented with text labels ISTD, plus graphic image ED, EDTX, UP, TI, FA, DETN, CLMN  DETD, CLM	D STDG D ISTD D ISTDG D TRIAL  D TX
HIT KWIC OCC	Hit term(s) and field(s) Up to 50 words before and after hit term(s) (KeyWord-In-Context) Number of occurrences of hit term(s) and field(s) in which they occur	D HIT D KWIC D OCC

- (1) By default, patent numbers, application and priority numbers are displayed in STN Format. To display them in Derwent format, enter SET PATENT DERWENT at an arrow prompt. To reset display to STN Format, enter SET PATENT STN.
- (2) Custom display only.
- (3) You can combine this display field with the qualifier .PK (Patent Kind Code) to display the content for a certain publication level of a record, e.g. CLM.B3.
- (4) SCAN must be specified on the command line, i.e., D SCAN or DISPLAY SCAN.
- (5) If priority information is not available for a certain document, this information is taken from the application information of this document and marked with an asterisk (\*).

**DEFULL****SELECT, ANALYZE, and SORT Fields**

The SELECT command is used to create E-numbers containing terms taken from the specified field in an answer set.

The ANALYZE command is used to create an L-number containing terms taken from the specified field in an answer set.

The SORT command is used to rearrange the search results in either alphabetic or numeric order of the specified field(s).

You can combine all fields except FA with the qualifier .M to SELECT/ANALYZE the content of all publication levels.

Field Name	Field Code	ANALYZE/ SELECT (1)	SORT
Abstract (German and English)	AB	Y	Y
Abstract (German)	ABDE	Y	Y
Abstract (English)	ABEN	Y	Y
Accession Number	AN	Y	Y
Application Country	AC	Y	Y
Application Date	AD	Y	Y
Application Information	AI (AP, APPS)	Y (2)	Y
Application Number, Original	APO	Y	Y
Application Year	AY	Y	Y
Claims (German and English)	CLM	Y	N
Claims (German)	CLMDE	Y	N
Claims (English)	CLMEN	Y	N
Cooperative Patent Classification	CPC	Y	Y
Detailed Description (German and English)	DETD	Y (3)	N
Detailed Description (German)	DETDDE	Y (3)	N
Detailed Description (English)	DETDEN	Y (3)	N
Document Type	DT	Y	Y
Entry Date	ED	Y	Y
Entry Date Full Text	EDTX	Y	Y
Field Availability	FA	Y	N
Graphic Image, Size	GIS	Y	Y
Graphic Image, Type	GIT	Y	N
International Patent Classification	IC	Y	N
Inventor	IN (AU)	Y	Y
Inventor, Country	IN.CNY	Y	Y
IPC (ICM, ICS, IPCI, IPCR)	IPC	Y	Y
IPC, Advanced Level Symbols	IPC.A	Y (4)	N
IPC, Advanced Level Symbols for Invention	IPC.AI	Y (4)	N
IPC, Initial	IPCI	Y	Y
IPC, Main	ICM	Y	Y
IPC, Reclassified	IPCR	Y	Y
IPC, Reform	IPC.REF	Y	N
IPC, Secondary	ICS	Y	Y
Language	LA	Y	Y
Language of Filing	LAF	Y	Y
Main Claim (German and English)	MCLM	Y	N
Main Claim (German)	MLCMDE	Y	N
Main Claim (English)	MCLMEN	Y	N
Number of Claims	CLMN	Y	Y
Number of Paragraphs in DETD	DETN	Y	Y
Occurrence Count of Hit Terms	OCC	N	Y
Patent Assignee/Patentee	PA (CS)	Y	Y
Patent Assignee, Country	PA.CNY	Y	Y
Patent Assignee, Address	PAA	Y	N
Patent Assignee Number	PAN	Y	Y
Patent Country	PC	Y	Y
Patent Information Publication Type	PIT	Y	Y
Patent Kind Code	PK	Y	Y
Patent Number	PI (PN, PATS)	Y (default)	Y

**SELECT, ANALYZE, and SORT Fields cont'd)**

Field Name	Field Code	ANALYZE/ SELECT (1)	SORT
Patent Number, Original	PNO	Y	Y
Patent Number/Kind Code	PNK	Y	Y
Pre-IPC8 Symbols from the ICM and first IPC8 values from 2006-present	IPC.F	Y (4)	Y
Priority Country	PRC	Y	Y
Priority Date	PRD	Y	Y
Priority Date, First	PRDF	Y	Y
Priority Number	PRN (PRAI)	Y	Y
Priority Number, Original	PRNO	Y	Y
Priority Year	PRY	Y	Y
Priority Year, First	PRYF	Y	Y
Publication Date	PD	Y	Y
Publication Year	PY	Y	Y
Related Patent Country	RLC	Y	Y
Related Application Number	RLN	Y	Y
Related Application Date	RLD	Y	Y
Related Application Year	RLY	Y	Y
Title (German and English)	TI	Y	Y
Title (German)	TIDE	Y	Y
Title (English)	TIEN	Y	Y
Update Date	UP	Y	Y

(1) HIT may be used to restrict terms extracted to terms that match the search expression used to create the answer set, e.g., SEL HIT TI.

(2) Selects or analyzes application numbers with /AP appended to the terms created by SELECT.

(3) Appends /BI to the terms created by SELECT.

(4) Appends /IPC to the terms created by SELECT.

DEFULL

## Sample Records

### DISPLAY ALL (STN format)

L5 ANSWER 1 OF 2 DEFULL COPYRIGHT 2013 QUESTEL on STN.  
 AN 1996035631 DEFULL ED 20131112 UP 20131112 EDTX 20131112  
 TIEN Holding or lifting magnet with reduction, or switch-off of holding force  
 TIDE Haftmagnet mit Vorrichtung zum Verringern oder Abschalten der Haftkraft  
 IN GRUBER BRUNO, DE  
 PA Gruber, , Bruno, 82140 Olching,, DE  
 LAF German  
 LA German  
 DT Patent; (Fulltext)  
 PIT DEAI DOC. LAID OPEN (FIRST PUBLICATION)  
 PI DE 19650490 A1 19980610  
 AI DE 1996-19650490 19961205  
 PRAI DE 1996-19650490 19961205  
 IPCR H01F0007-04 [I,A]  
 CPC H01F0007-04

ABEN

The ferromagnetic bar (2) has a non-magnetic or weakly-magnetic zone (4) in its middle region in transverse direction. The two magnets (1) are held together by a frame (5), serving also as a displaceable handle (9). Pref. a magnet is displaceably fitted between two stationary ferromagnetic bars. Typically the non- or weakly magnetic zone extends up to the handle and consists of a non-magnetic material, such as non-ferrous metal or plastics, while it is soldered, screwed, or glued to the ferromagnetic bar. The zone may be formed by a series of transverse bores, or slots.

ABDE

Die Erfindung betrifft einen Haftmagnet, bei dem die Haftkraft verringert oder abgeschaltet werden kann, damit dieser von einem anhaftenden Teil oder von einer Metallplatte mit geringem Kraftaufwand wieder getrennt werden kann.

DETDEN

[0001] The Invention concerns a Detention Magnet with that the Adhesive force to be reduced or switched off can, so that this from an adhering Part or from a Metal Plate with small Energy Expenditure again can be separated.

Setting Of Tasks

[0002] Task of the Invention is it to create a Detention or a Lifting Magnet which exhibits on the one hand the full Adhesive force, and on the other hand with small Departure Strength again to solve by hand leaves itself. Also the Detention Magnet is to be able to be solved fastened with the same Handle by Pressing in slightly and by Pulling away again.

[0003] The Task is solved According To Invention according to the Patent Claim 1.

Execution Example

[0004] The Design shows the Detention Magnet the according to invention, with two Magnet 1, which ferrousmagnetic Bar 2, with which Mounting Hole 3 and the Handle 9, which non or weak-magnetic Zone 4, which also as Operating Grasp serving 5 for the Magnets 1, which are kept loose to Magnet Attachment 6 with the Holding Pegs 7 in a Drilling 8 5, and one of the two opposite Grasp Plates 11.

CLMEN

1. Detention Magnet marked by Device for Reducing or Switching off the Adhesive force by the fact that reciprocally at a ferrousmagnetic Bar adjustable in Longitudinal Direction (2) Magnets (1) is attached the fact that the ferrousmagnetic Bar within the Central Range in Transverse Direction a non-magnetic or weak-magnetic narrow Zone (4) exhibits, and

that both Magnets of a Framework (5) to be held together, which serves also as adjustable Handling Grasp.

2. Detention Magnet according to claim 1, by the fact characterized that a Magnet (1) between 2 which are certain ferrousmagnetic Bars (2) is adjustably attached.

3. Detention Magnet according to claim 1 and 2, by the fact characterized that non or weak-magnetic Zone (4) itself up to the Handle (9) extended, and from a non-magnetic Material such as Non-ferrous Metal or Plastic exists.

4. Detention Magnet according to claim 1 to 2, by the fact characterized that non or weak-magnetic Zone (4) from Plastic or Non-ferrous Metal exists soldered, and with the ferrousmagnetic Bar (2), bolted or stuck together.

## DETDE

[0001] Die Erfindung betrifft einen Haftmagnet bei dem die Haftkraft verringert oder abgeschaltet werden kann, damit dieser von einem anhaftenden Teil oder von einer Metallplatte mit geringem Kraftaufwand wieder getrennt werden kann.

## Aufgabenstellung

[0002] Aufgabe der Erfindung ist es, einen Haft- oder Hebemagneten zu schaffen, der einerseits die volle Haftkraft aufweist, und andererseits sich von Hand mit geringer Abzugskraft wieder loesen laesst. Auch soll der Haftmagnet mit demselben Handgriff durch Andruecken befestigt und durch Wegziehen wieder geloest werden koennen.

[0003] Erfindungsgemaess wird die Aufgabe entsprechend dem Patentanspruch 1 geloest.

## CLMDE

1. Haftmagnet mit Vorrichtung zum Verringern oder Abschalten der Haftkraft dadurch gekennzeichnet, dass beidseitig an einer in Laengsrichtung verschiebbaren ferromagnetischen Stange (2) Magnete (1) angebracht sind, dass die ferromagnetische Stange im Mittelbereich in Querrichtung eine nichtmagnetische oder schwachmagnetische schmale Zone (4) aufweist, und dass beide Magnete von einem Rahmen (5) zusammengehalten werden, der auch als verschiebbarer Handhabungsgriff dient.

2. Haftmagnet nach Anspruch 1, dadurch gekennzeichnet, dass ein Magnet (1) zwischen 2 feststehenden ferromagnetischen Stangen (2) verschiebbar angebracht ist.

3. Haftmagnet nach Anspruch 1 und 2, dadurch gekennzeichnet, dass die nicht- oder schwachmagnetische Zone (4) sich bis zum Handgriff (9) erstreckt, und aus einem nichtmagnetischen Material wie Buntmetall oder Kunststoff besteht.

## DISPLAY ISTD.M

ACCESSION NUMBER: 2011022904 DEFULL  
 ENTRY DATE: 20131112  
 UPDATE DATE: 20131112  
 ENTRY DATE (FULLTEXT): 20131112  
 TITLE (ENGLISH): Pivotal socket spanner insert, has spring element arranged in hole and providing spring force to engaging element, and drive instruments adjusted and joined by insert and held by engaging element and another engaging element  
 TITLE (GERMAN): Schwenkbarer Steckschlusseinsatz  
 INVENTOR(S): LIU WEN-PIN, TW  
 PATENT APPLICANT(S): Liu, Wen-Pin Taichung, TW  
 AGENT: Viering, Jentschura & Partner, 81675, Muenchen, DE  
 LANGUAGE OF FILING: German  
 LANGUAGE OF PUBL.: German  
 DOCUMENT TYPE: Patent; (Fulltext)  
 PATENT INFORMATION TYPE: DEAL DOC. LAID OPEN (FIRST PUBLICATION)  
 PATENT INFORMATION: DE 102011051163 A1 20121220  
 APPLICATION INFO.: DE 2011-10201105116320110617  
 PRIORITY INFO.: DE 2011-102011051163 20110617

**DEFULL**

IPC ORIGINAL: B25B0013-06 [I,A]; B25B0013-46 [I,A]  
 CPC CLASSIF. B25B0023-0028; B25B0015-001

ACCESSION NUMBER: 2011022904 DEFULL  
 ENTRY DATE: 20131112  
 UPDATE DATE: 20131112  
 ENTRY DATE (FULLTEXT): 20131112  
 TITLE (ENGLISH): Tilttable Socket For Wrenches  
 TITLE (GERMAN): Schwenkbarer Steckschluesseinsatz  
 INVENTOR(S): LIU WEN-PIN, TW  
 PATENT APPLICANT(S): Liu, Wen-Pin Taichung, TW  
 AGENT: Viering, Jentschura & Partner, 81675, Muenchen, DE  
 LANGUAGE OF FILING: German  
 LANGUAGE OF PUBL.: German  
 DOCUMENT TYPE: Patent; (Fulltext)  
 PATENT INFORMATION TYPE: DEB4 PATENT (SECOND PUBLICATION)  
 PATENT INFORMATION: DE 102011051163 B4 20130207  
 APPLICATION INFO.: DE 2011-10201105116320110617  
 PRIORITY INFO.: DE 2011-102011051163 20110617  
 IPC ORIGINAL: B25B0013-06 [I,A]; B25B0013-46 [I,A]  
 CPC CLASSIF. B25B0023-0028; B25B0015-001

**DISPLAY STDG**

L11 ANSWER 2 OF 400904 DEFULL COPYRIGHT 2013 QUESTEL on STN.  
 AN 2013009855 DEFULL ED 20131129 UP 20131129 EDTX 20131129  
 TIDE Hebelbetaetigtes Druckschloss  
 IN BENNETT NICHOLAS PAUL, GB; KEMPSON PHILIP JOHN, GB  
 PA Southco, Inc. Pa. Concordville, US  
 AG WSL Patentanwaelte Partnerschaftsgesellschaft, 65185, Wiesbaden, DE  
 LAF German  
 LA German  
 DT Patent; (Fulltext)  
 PIT DET5 TRANSLATION OF PUBL. OF INTERNATIONAL APPLICATION [FROM 20070503  
 ONWARDS]  
 PI DE 112013000007 T5 20131121  
 AI DE 2013-112013000007 20130206  
 RLN WO 2013-US24862 20130206  
 PRAI US 2012-61596187 20120207  
 US 2012-61596571 20120208  
 US 2012-61597749 20120211  
 WO 2013-US24862 20130206  
 IPCI E05C0005-00 [I,A]; F24C0015-02 [I,A]  
 CPC E05C0003-06

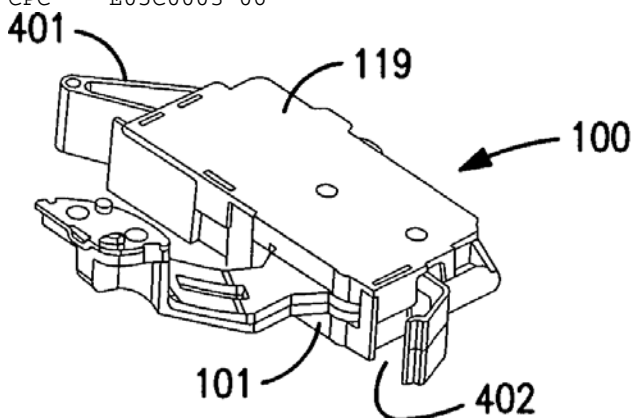

**In North America**  
 CAS  
 STN North America  
 P. O. Box 3012  
 Columbus, Ohio 43210-0012 U.S.A.

CAS Customer Center:  
 Phone: 800-753-4227 (North America)  
 614-447-3700 (worldwide)  
 Fax: 614-447-3751  
 Email: [help@cas.org](mailto:help@cas.org)  
 Internet: [www.cas.org](http://www.cas.org)

**In Europe**  
 FIZ Karlsruhe  
 STN Europe  
 P. O. Box 2465  
 76012 Karlsruhe  
 Germany  
 Phone: +49-7247-808-555  
 Fax: +49-7247-808-259  
 Email: [helpdesk@fiz-karlsruhe.de](mailto:helpdesk@fiz-karlsruhe.de)  
 Internet: [www.stn-international.com](http://www.stn-international.com)

**In Japan**  
 JAICI (Japan Association for  
 International Chemical Information)  
 STN Japan  
 Nakai Building  
 6-25-4 Honkomagome, Bunkyo-ku  
 Tokyo 113-0021, Japan  
 Phone: +81-3-5978-3601 (Technical Service)  
 +81-3-5978-3621 (Customer Service)  
 Fax: +81-3-5978-3600  
 Email: [support@jaici.or.jp](mailto:support@jaici.or.jp) (Technical Service)  
[customer@jaici.or.jp](mailto:customer@jaici.or.jp) (Customer Service)  
 Internet: [www.jaici.or.jp](http://www.jaici.or.jp)